

# Paasche® FP-1/32 Flow Pencil

## OPERATING INSTRUCTIONS & REPLACEMENT PARTS



**WARNING:** Striping materials may be harmful if inhaled or allowed to come into contact with the skin or eyes. Consult the product label and Material Safety Data Sheet supplied for the spray material. Follow all safety precautions. **CAUTION:** Well Ventilated Area Required to remove fumes.

Comes with LN-1/32 (Assembled) and LN-1/64, 3/64, and 1/16 Nibs loose  
Total Length of Flow Pencil is 5 -1/2 inches.  
HAPK Kit comes with one size nib only

### INTRODUCTION:

The **FP-1/32 Flow Pencil** is used extensively by Designers, Sculptors, Hobbyists, Crafters, Ceramicists, Artists, Furniture Manufacturers, and others to beautify their products. The Flow Pencil is easy to control and operate.

### MIXING COLORS:

1. Proper mixing of colors is essential for continuous and uninterrupted striping.
2. Mix colors into a free flowing consistency, strain to remove any lumps.
3. Do not mix color in cup of Flow Pencil, use a separate container and pour into cup only when color flows freely.

### COLOR ADJUSTMENTS:

1. Remove **FP-10 Cover**, and pour premixed free flowing color into cup, then replace cover.
2. Turning the **MU-72 Adjusting Screw** will control the stroke of the **MU-65 Finger Lever Assembly** which controls the flow of color.

### OPERATION:

1. Hold the **FP-1/32 Flow Pencil** in your hand as you would a pencil or brush and place your finger lightly over the **MU-65 Finger Lever**. When ready to stripe, pull back on the **MU-65 Finger Lever**. The Flow Pencil should be moved in a backward motion (away from the paint) after the color has begun to flow, never push it into the paint.
2. Regulate the flow to the desired feed rate by turning **MU-72 Adjusting Screw**.
3. Keep vent hole in the **FP-10 Cover** open.
4. Practice striping before working on finished product.
5. Correct adjustment of controls and skill of operation will result in uninterrupted and continuous striping.

### CARE AND CLEANING:

1. Before storing **FP-1/32 Flow Pencil** clean it thoroughly. Empty remaining color from the cup and rinse it with solvent. Pull back on the **MU-65 Finger Lever** and allow solvent to flow through cup, shell and nib.
2. If color has hardened in hole of nib use a tooth pick or needle dipped in solvent to remove accumulation.
3. **MU-49L Needle** is held in position by **MU-57 Needle Chuck** and **VL-141 Locknut**. Remove the needle by unscrewing the **MU-71 Handle** and removing the spring. Loosen the **VL-141 Locknut** and then remove the needle for cleaning.

### ADJUSTING OR REPLACING WORN PACKING WASHER:

1. If **PTFE Packing-#6** becomes worn or loose it must be tightened or replaced.
2. You will need a small screwdriver to remove or tighten the **Packing Nut**.
3. When replacing your **PTFE Packing** press **Packing** onto the **Packing Nut-#6**. Use a small screwdriver to tighten **packing nut** into shell until it is tight then back out one-half turn, may vary.
4. Now insert needle - you should feel a slight resistance. If too loose or too tight adjust the **Packing Nut** with screwdriver until you feel some slight resistance.
5. Now completely re-assemble guts of Flow Pencil.

Paasche Airbrush Co.  
9511 58th Place  
Kenosha, WI 53144  
Phone: (800) 621-1907  
Website: [www.paascheairbrush.com](http://www.paascheairbrush.com)  
E-Mail: [info@paascheairbrush.com](mailto:info@paascheairbrush.com)

**CAUTION: OVER TIGHTENING CUP WILL CAUSE TRIGGER TO MALFUNCTION.**

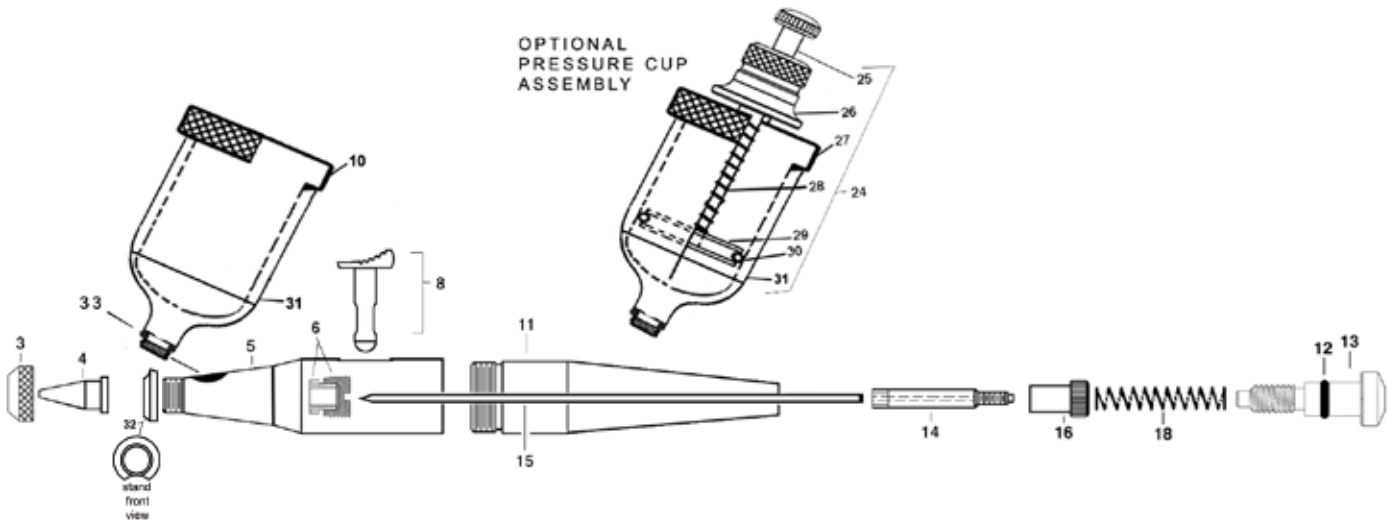

**FP-1/32 FLOW PENCIL (WITH EXTRA NIBS: LN-1/64, 3/64 AND 1/16)**

**HAPK KIT comes with one size nib only**

**Nibs are grooved as follows:**

**LN-1/64 has one (1) groove**

**LN-1/32 has two (2) grooves**

**LN-3/64 has three (3) grooves**

**LN-1/16 has four (4) grooves**

<u>No.</u>	<u>Part No.</u>	<u>Description</u>	<u>No.</u>	<u>Part No.</u>	<u>Description</u>
3.	<b>*MU-9</b>	Tip Nut	31.	<b>*FP-6</b>	Cup (only) Aluminum
4.	<b>**LN-1/32</b>	Nib (1/64, 3/64 & 1/16 Sizes)	32.	<b>MU-77</b>	Stand
5.	<b>*MU-48A</b>	Shell Assembly	33.	<b>AE-43</b>	"O" Ring
6.	<b>**MU-612</b>	PTFE Packing & Packing Nut	<b>(OPTIONAL PRESSURE CUP)</b>		
8.	<b>**MU-65</b>	Finger Lever Assembly	24.	<b>FP-45</b>	(Complete assembly)
10.	<b>*FP-10</b>	Basic Cover (only)	25.	<b>**MU-25</b>	Rod & Cap Assembly
11.	<b>MU-71</b>	Handle	26.	<b>*MU-69</b>	Nut
12.	<b>3A-4</b>	"O" Ring	27.	<b>*FP-5</b>	Pressure Cover (only)
13.	<b>**MU-72</b>	Adjusting Screw	28.	<b>MU-26</b>	Spring
14.	<b>**MU-57</b>	Needle Chuck	29.	<b>*FP-9</b>	Piston
15.	<b>***MU-49L</b>	Needle	30.	<b>****FP-8</b>	(FDA) "O" Ring
16.	<b>**VL-141</b>	Locknut	31.	<b>*FP-6</b>	Cup (only) Aluminum
18.	<b>***VL-140</b>	Spring	33.	<b>AE-43</b>	"O" Ring (rubber)

**Contains Aluminum....\***

**Contains Brass....\*\***

**Contains Stainless Steel....\*\*\***

**Contains FDA Approved Silicone....\*\*\*\***